

One thing is of primary importance for modern combustion installations: efficiency. That applies to the operation of the equipment as well as to its erection and commissioning.

**LAMTEC has the right solution:
the ETAMATIC OEM**

As the name suggests (ETA is the Greek letter η used in engineering as the symbol for efficiency), the ETAMATIC OEM is characterized by efficiency in every aspect. Its compact form contains everything needed for complete burner control.

It combines the advantages of an electronic firing compound with up to 4 positioning elements with an electronic burner sequence control. Since a output regulator, O_2 controller or CO controller (with gas), leakage test and flame monitor are also integrated, you have everything you need to control and monitor your burner in one device. Fail-safe. This gives you the solution to nearly all your firing tasks. Safety interlock circuits, sensors and detectors are connected directly to the ETAMATIC OEM. The need for supplementary relays and wiring is vastly reduced.

The ETAMATIC OEM is designed to be mounted at the burner itself. An integrated device like the ETAMATIC OEM also offers significant advantages during commissioning. Through minimization of the wiring and the unified user interface, sources of error are minimized from the very beginning, while the search for faults is assisted through appropriate and relevant advice.

The ETAMATIC OEM is available with 4 three-state step outputs, or with one continuous output (for rotary speed control) and 3 three-state step outputs.

The firing mechanism and the compound can be parameterised to adapt them to very different firing tasks. Separate settings can be made for oil and gas with and without a pilot burner. The integrated leakage test can optionally be made before ignition or after switch-off. Start-up without pre-ventilation with gas in accordance with EN676 is also possible.

The compound curves that have been set can be shifted during operation by the integrated O_2 control. This enables compensation for factors that could influence the combustion.

If you are burning gas, you can do even more: the LAMTEC CO control is able to run your burner with the maximum of possible efficiency.

Operating and error messages are displayed in plain text in the appropriate language. The operating hours counter is integrated, and also counts the burner operating hours with gas and oil. The start-ups for gas and oil are also separately counted.

If desired, the ETAMATIC OEM can also perform output regulation of the burner. It is possible to switch between 2 sets of values, e.g. for reduced night-time power or heat holding operation. External set value adjustment (weather response) and start-up control can be used.

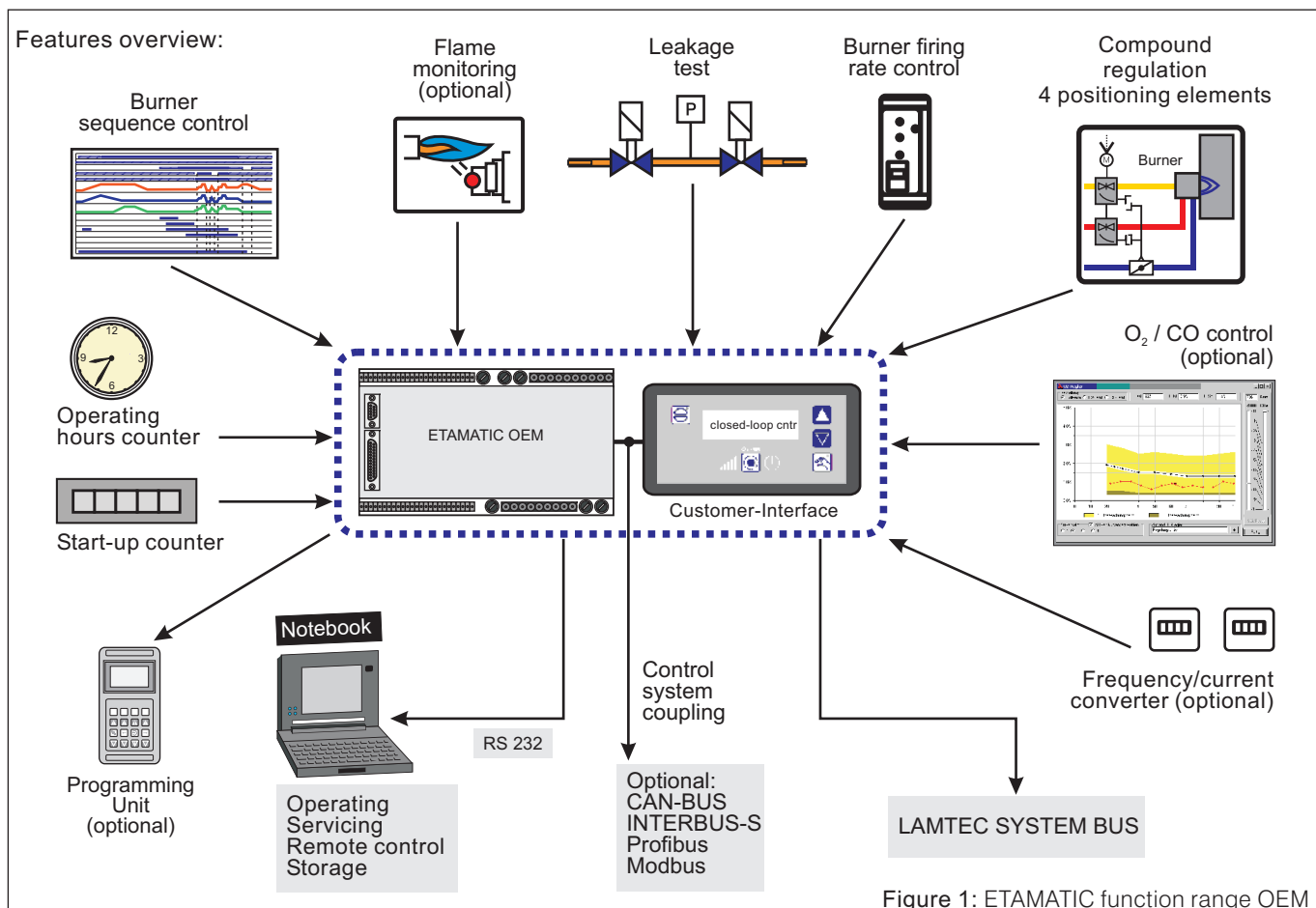

Figure 1: ETAMATIC function range OEM

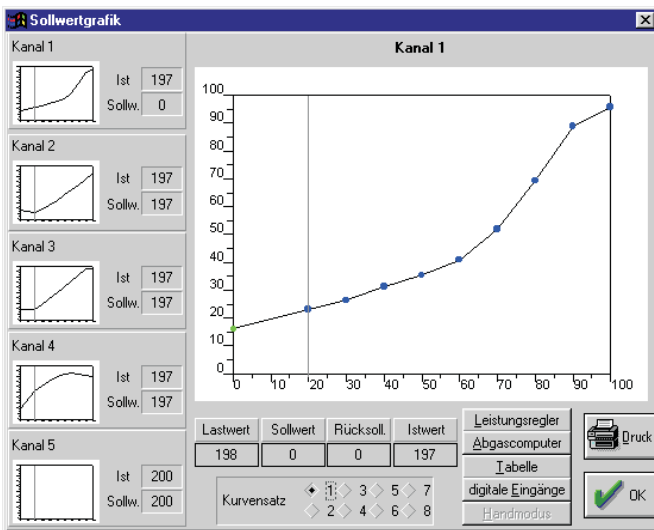

Figure 2: Visualisation of the compound curves through the remote control software

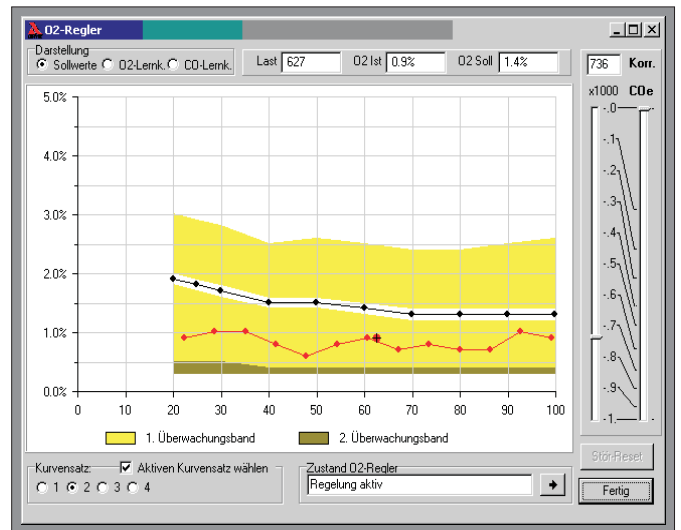

Figure 3: Visualisation of the O₂ /CO setpoint-curve with its monitoring-band-gaps when using the ETAMATIC's OEM integrated O₂ /CO control

An ETAMATIC OEM always has a LAMTEC SYSTEM BUS connection on board. The LAMTEC SYSTEM BUS links LAMTEC devices together. Fast, easy and with less wiring effort!

A software module O₂ control, if desired CO/O₂ control, is integrated into the ETAMATIC OEM. In combination with the O₂/CO-measurement devices LT1/LT2 via the LAMTEC SYSTEM BUS, every firing installation can be maintained constantly at the ideal operating point, independently of environmental conditions such as temperature and air pressure. The ETAMATIC OEM can be effectively combined with existing control system. It "speaks" the language of almost every conventional fieldbus.

The ETAMATIC OEM has been tested by TÜV, and

satisfies both the relevant European Standards (EN) and the requirements of TRD 604 for continuous operation.

An additional PC interface provides valuable assistance for the work of commissioning the ETAMATIC OEM. A laptop can be used to control the device remotely, and both the set configuration and the curve data can be archived. If it should ever be necessary, a replacement unit can be prepared for operation within seconds: the stored data is simply read in.

The ETAMATIC OEM can even be interrogated from your office if an industrial modem is used. Should a malfunction occur, the cause can be detected without having to be on site.

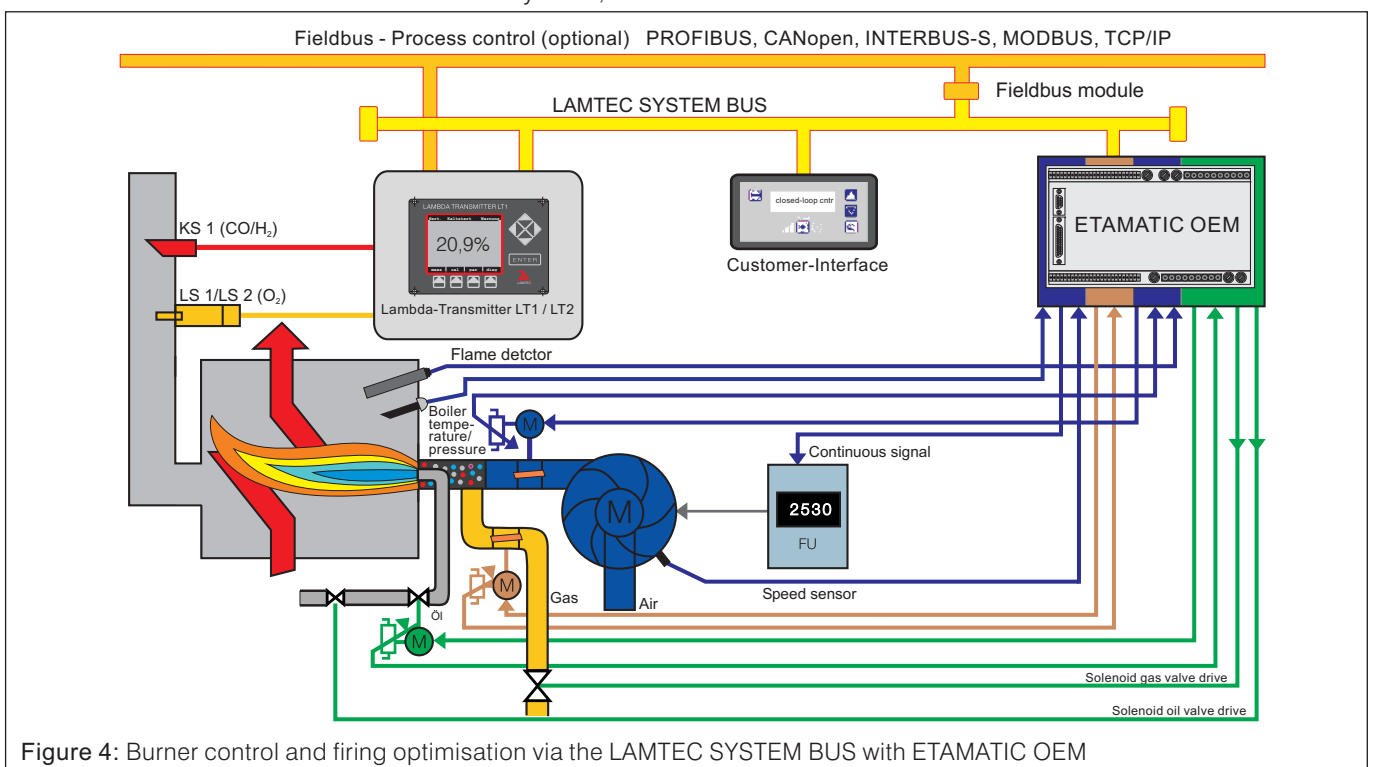

Figure 4: Burner control and firing optimisation via the LAMTEC SYSTEM BUS with ETAMATIC OEM

Electrical power supply	from 115 V -15 % to 230 V +10 % 50/60 Hz To be used only in a grounded power line network!	Resolution per analog input	999 digits, 10 bits
Power consumption	approx. 50 VA	Three-state-step Recommended run time of the positioning drive	30 s...60 s distance max. 10 m
Ambient temperature Operation Transport and storage	+0 °C...+ 60° C -25 °C...+ 60° C	Constant outputs Load	0...10 V > 5 kΩ 0/4...20 mA < 600 Ω
Customer interface	Alphanumeric display, 2 x 16 characters can display load value, status, O ₂ -value, flame Intensity, running text display	Digital outputs	gas valve 1 and 2 oil valve fan on oil pump ignition valves
Programming Unit	4 x 16 characters can display with softkeys and setup-assistent	Storage of the set values and variable data	in EEPROM, up to 20 (type 11) points per curve with linear interpolation
Permiss. ambient humidity	Class F, DIN 40 040	Number of curve-sets	2 per channel (e.g. for oil/gas combined burner)
Inputs and outputs	14 digital inputs, 24V 12 digital outputs, 230V 1 analog output (ETAMATIC/S OEM) 3 analog inputs	Number of programmings	Unlimited (EEPROM)
Digital signal inputs	The ETAMATIC's OEM self-tests will not allow the parasitic capacitance on the lines connected to the digital inputs to exceed 2.2 μF. The length of the cables should not exceed 10 m	Interfaces	1 serial interface on 25-pole sub-D socket only addressable with adapter RS 232 (standard setting 19200 baud, no parity, 8 data bits, 1 stop bit) and LAMTEC SYSTEM BUS (length max. 500 m)
Load preset	Selectable potentiometer 1 - 5 kΩ, (0/4...20mA) current signal or three-state-step positioning output, direct PT 100 actuation (if the load regulator is used)	BUS coupling	Via LSB adapter BUS card optional for these systems:
Analog inputs	Selectable potentiometer 1 - 5 kΩ or 0/4...20 mA current signal. Optional: Direct actuation Namur transducer or three-wire DC sensor length max. 10 m		Interbus-S (Phoenix) Profibus Modbus CAN-BUS Ethernet (Modbus TCP)

Dimensional drawings

